

APPLICATION NOTE

QS DETECTORS PIN-OUTS AND DESCRIPTIONS

QS-IL, QS-IF AND QS-THZ HYBRID PYROELECTRIC DETECTORS

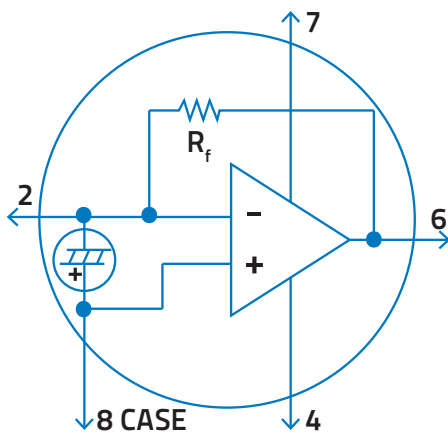

Figure 1: QS-IL, QS-IF and QS-THZ Pin-Out

Pin-Out

These three families of Hybrid Pyroelectric Detectors include a LiTaO_3 detector element, a low noise Current Mode op amp and a large feedback resistor. The QS-IL and QS-THZ are designed for optimum R_V and NEP at 5 Hz. The QS-IF incorporates a high bandwidth op amp and a slightly smaller feedback resistor for flat voltage output up to 1000 Hz.

The three series share the same Pin-Out, as shown in Fig. 1. Note that Pins 1, 3, and 5 are not connected inside the TO package and therefore are not part of the electronics.

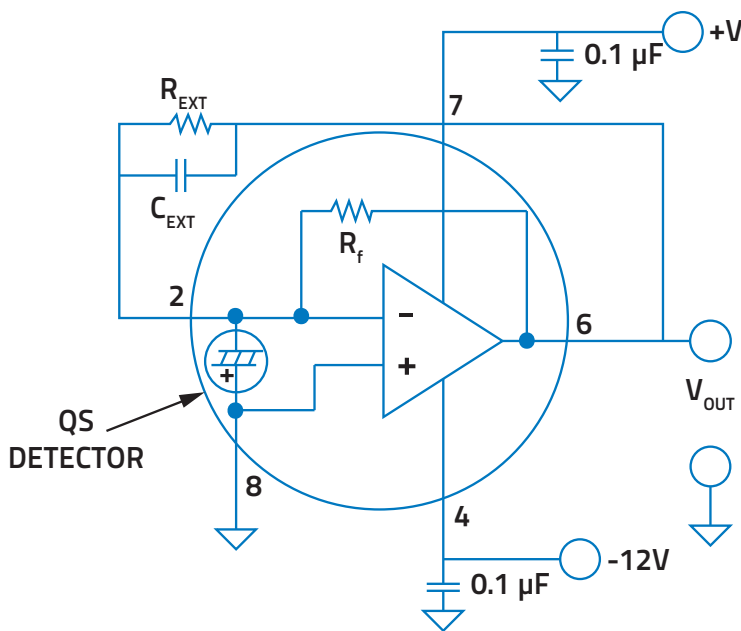

Figure 2: QS-IL, QS-IF and QS-THZ circuitry

Schematic of Operation

The circuit on Fig. 2 shows the typical connections made to the hybrid detector. $\pm 12\text{ V}$ powers the op amp. You can add an external feedback resistor to increase the bandwidth of the detector and/or lower the voltage responsivity. We recommend cutting pin 2 off if there is no plan to use an external component. This way, the detector's performance will be optimized.

APPLICATION NOTE

QS-VL HYBRID PYROELECTRIC DETECTORS

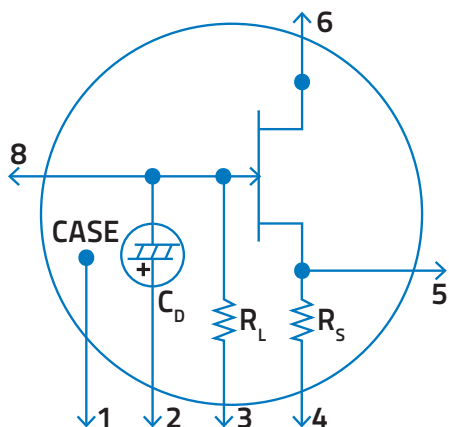

Figure 3: QS-VL Pin-Out

Pin-Out

This family of Hybrid Pyroelectric Detectors includes a LiTaO_3 detector element, a low noise FET Voltage Mode preamp and a large feedback resistor. The QS-VL detectors are designed for optimum R_V and NEP at 5 Hz.

The Pin-Out is shown in Fig. 3. Note that Pin 7 is not connected inside the TO package and therefore is not part of the electronics.

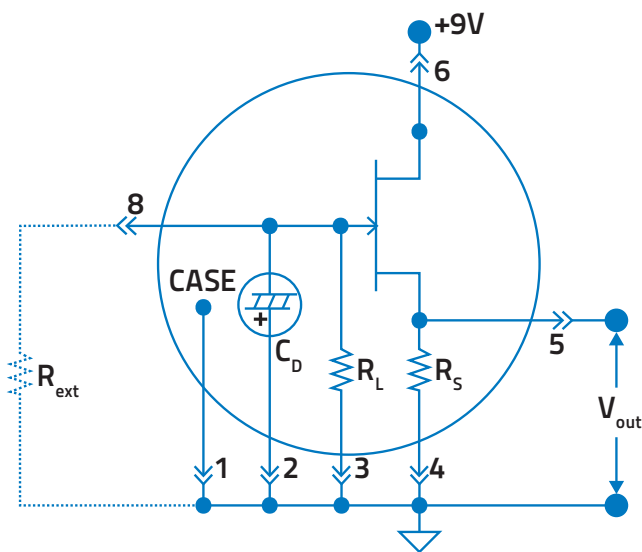

Figure 4: QS-VL circuitry

Schematic of Operation

The circuitry on Fig. 4 shows the typical connections made to the hybrid detector in a source follower circuit. You can add an external Load Resistor between Pin 8 and GND. This effectively allows you to change the voltage responsivity and/or the bandwidth of the detector.

APPLICATION NOTE

QS-L AND QS-H DISCRETE PYROELECTRIC DETECTORS

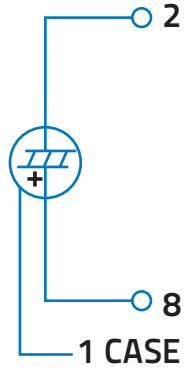

Figure 5: QS-L Pin-Out

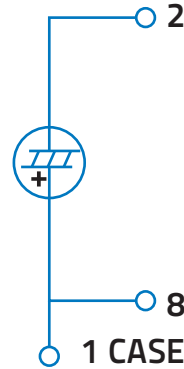

Figure 6: QS-H Pin-Out

MECHANICAL DETAILS OF THE QS DETECTORS

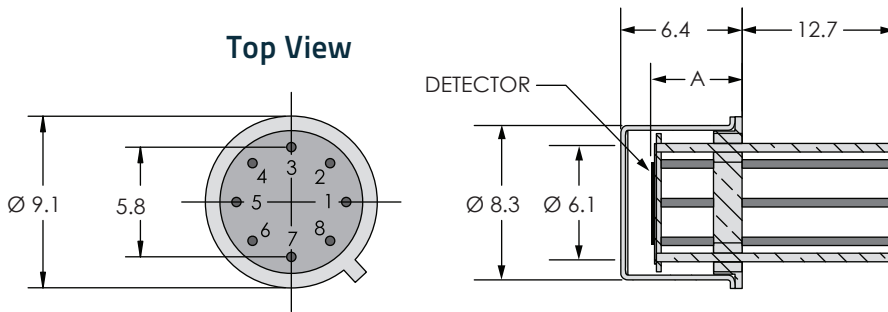

Figure 7: QS detectors mechanical details (T05-Based)

MODEL	DIM. A
QS-L	4.6
QS-H	2.0
QS-VL	4.6
QS-IF	4.6
QS-IL	4.6

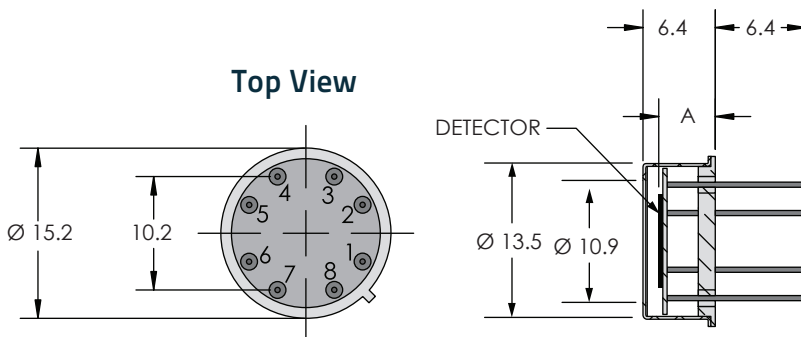

Figure 8: QS detectors mechanical details (T08-Based)

MODEL	DIM. A
QS-L	4.6
QS-H	2.0
QS-VL	4.6
QS-IF	4.6
QS-IL	4.6