

USER MANUAL

FLASH

Handheld Laser Probe



gentec-eo

121-102019

WWW.GENTEC-EO.COM

Warranty

First Year Warranty

The Gentec-EO thermal power detectors carry a one-year warranty (from date of shipment) against material and /or workmanship defects when used under normal operating conditions. The warranty does not cover recalibration, or damages related to misuse.

Gentec-EO will repair or replace at our option any FLASH which proves to be defective during the warranty period; except in the case of product misuse.

Any unauthorized alteration or repair of the product is also not covered by the warranty.

The manufacturer is not liable for consequential damages of any kind.

In the case of a malfunction, contact your local Gentec-EO distributor or the nearest Gentec-EO office to obtain a return authorization number. Return the material to the appropriate address below.

Contacting Gentec Electro-Optics Inc.

To help us answer your calls more efficiently please have the model number of the detector you are using, ready before calling Customer Support.

All customers:

Gentec-EO, Inc.
445 St-Jean-Baptiste, Suite 160
Quebec, QC, G2E 5N7
Canada

Tel: (418) 651-8003
Fax: (418) 651-1174
Email: service@gentec-eo.com
Web: www.gentec-eo.com

Lifetime Warranty

Gentec-EO will guarantee any FLASH detector for its lifetime, as long as it has been returned for recalibration annually, from the shipment date. This warranty includes parts and labor for all routine repairs including normal wear under normal operating conditions.

Gentec-EO will inspect and repair the detector during the annual recalibration. Repairs at other times will be at Gentec-EO's option.

The cost of annual recalibration, or consequential damages from using the detector, is not included.

The only condition is that the detector must not have been subject to unauthorized service or damaged by misuse. Misuse would include, but is not limited to: laser exposure outside Gentec-EO's published specifications, physical damage due to improper handling, and exposure to hostile environments. Hostile environments would include, but are not limited to: excessive temperature, vibration, humidity, or surface contaminants; exposure to flame, solvents or **water**; and connection to improper electrical voltage.

SAFETY INFORMATION

Do not use the Flash if the device looks damaged, or if you suspect that the Flash is not operating properly.

The user must wait for a while before handling the head of the detector after power is applied. Surfaces of the detector's head get very hot and there is a risk of injury if they are not allowed to cool down.

Note: This equipment has been tested and found to comply with the limits for a Class B digital device, pursuant to part 15 of the FCC Rules. These limits are designed to provide reasonable protection against harmful interference in a residential installation. This equipment generates, uses, and can radiate radio frequency energy and, if not installed and used in accordance with the instructions, may cause harmful interference to radio communications. However, there is no guarantee that interference will not occur with a particular installation. If this equipment does cause harmful interference to radio or television reception, which can be determined by turning the equipment off and on, it is suggested to try to correct the interference by taking one or more of the following steps:

- Reorient or relocate the receiving antenna.
- Increase the distance between the equipment and receiver.
- Connect the equipment to an outlet that is on a different circuit than the receiver.
- Consult the dealer or an experienced radio/TV technician for help.

Caution: Changes or modifications not expressly approved in writing by Gentec-EO Inc. may void the user's authority to operate this equipment.

TABLE OF CONTENTS

WARRANTY.....	II
TABLE OF CONTENTS.....	IV
1. FLASH SERIES HANDHELD LASER PROBE	1
1.1 Introduction.....	1
1.2 Basic operating instructions (Power mode)	2
1.3 Basic operating instructions (Energy mode).....	3
1.4 Replacing the batteries	4
1.4 Flash series specifications.....	5
1.4.1 Power mode	5
1.4.2 Energie mode	6
2 OPERATING INSTRUCTIONS	7
2.1 Activation of the device and measuring the power of a laser	7
2.2 Semi-continuous mode (Does not work in energy mode [Joule])	8
2.3 Wavelength selection (CO2 / YAG / Other).....	9
2.4 User's self calibration (see Appendix A for typical wavelength correction factors)	9
2.5 LCD backlight	10
2.6 Error Cases.....	11
2.7 Displays over 10000 W (Only for the FLASH-10K).....	11
2.8 Using the FLASH in energy mode (Only for the FLASH-500 and FLASH-IPL).....	12
2 GENERAL INFORMATION.....	13
2.1 General instructions.....	13
2.2 Safety operation notes.....	14
2.3 Damage to the optical absorber material	14
DECLARATION OF CONFORMITY	16
APPENDIX A: TYPICAL WAVELENGTH CORRECTION	17
APPENDIX B: OPTIONAL FLASH STAND.....	18
APPENDIX C: WEEE DIRECTIVE	19

1. FLASH SERIES HANDHELD LASER PROBE

1.1 Introduction

The Gentec-EO Flash Series Handheld laser probe family includes the Flash-500-55, the Flash-500-10S-IPL, the Flash-500-20R5-IPL, the Flash-3K-55, the Flash-6K-55 and the Flash-10K-55.

- The Flash-500-55 detector has dimensions of 88 mm x 35 mm x 335 mm and an aperture of 55 mm.
- The Flash-500-10S-IPL detector has dimensions of 88 mm x 35 mm x 335 mm and an aperture of 10X10 mm.
- The Flash-500-20R5-IPL detector has dimensions of 88 mm x 35 mm x 335 mm and an aperture of 20X5 mm.
- The Flash-3K-55 detector has dimensions of 88 mm x 45 mm x 335 mm and an aperture of 55 mm.
- The Flash-6K-55 detector has dimensions of 88 mm x 36 mm x 335 mm and an aperture of 55 mm.
- The Flash-10K-55 detector has dimensions of 88 mm x 46 mm x 335 mm and an aperture of 55 mm.
- The high power surface absorber sensors are designed for use at high average power densities.

The Flash detectors can measure between

- ± 0.1 W (noise equivalent power) and 500 W of average power for Flash-500-55
 ± 0.5 J (noise equivalent energy) and 350 J of energy for the Flash-500-10S-IPL, Flash-500-20R5-IPL or FLASH-500-55 in energy mode
- ± 5 W (noise equivalent power) and 3000 W of average power for Flash-3K-55
- ± 20 W (noise equivalent power) and 6000 W of average power for Flash-6K-55
- ± 30 W (noise equivalent power) and 10000 W of average power for Flash-10K-55

Flash detectors can be supplied with a stand (optional).

For cases where the Flash detector doesn't have an adjustment or a calibration at a specific wavelength in one of the three pre-set modes(CO₂, YAG, Other), you can use your "*Wavelength Correction Factor*" to adjust the power you read to a power corrected for a particular wavelength with the detector self-calibration function.

Call your nearest Gentec-EO distributor to repair and/or to recalibrate the Flash. For Gentec-EO's nearest office contact information, see p. //, **Contacting Gentec Electro-Optics Inc.**

1.2 Basic operating instructions (Power mode)

A)

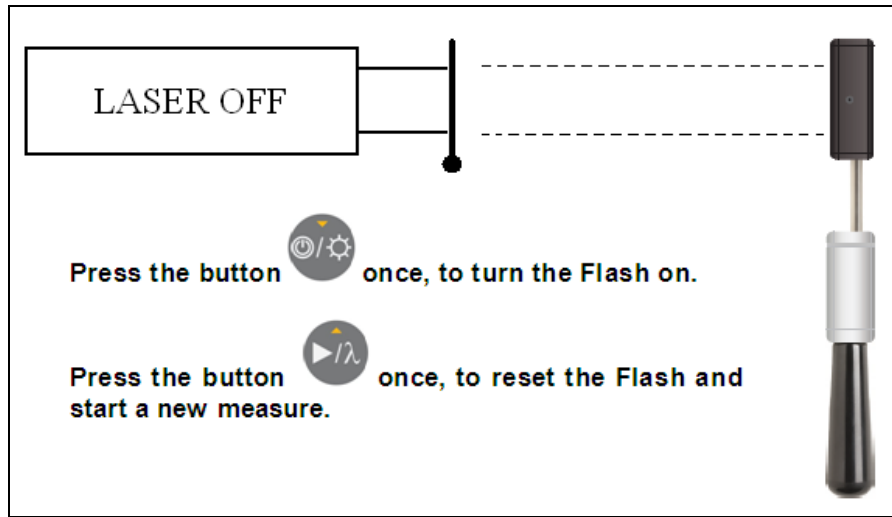

LASER OFF

Press the button  once, to turn the Flash on.

Press the button  once, to reset the Flash and start a new measure.

B)

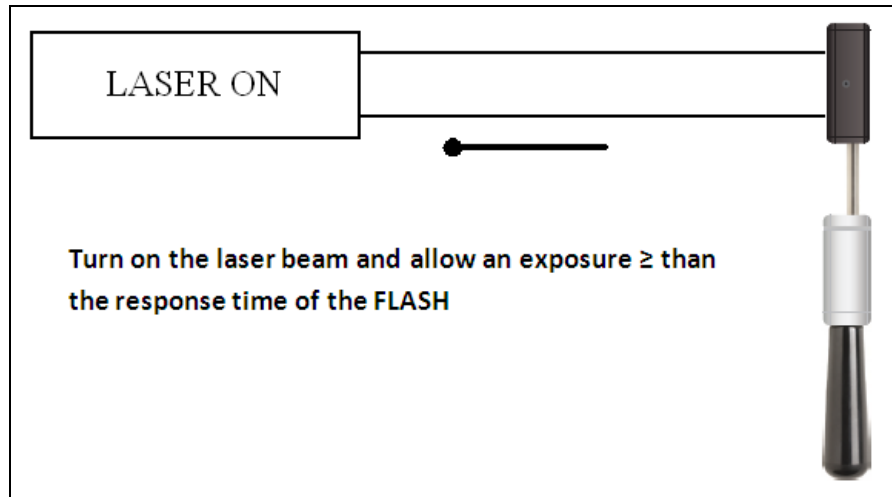

LASER ON

Turn on the laser beam and allow an exposure \geq than the response time of the FLASH

C)

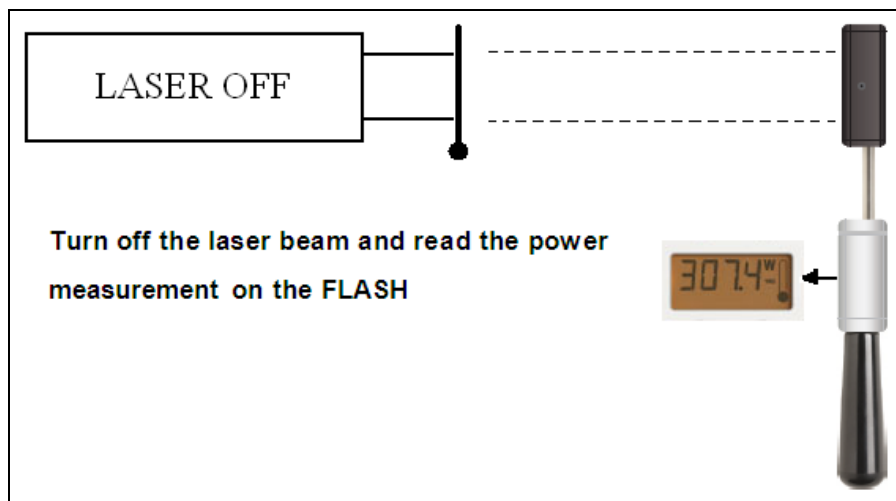

LASER OFF

Turn off the laser beam and read the power measurement on the FLASH

307.4 mW

1.3 Basic operating instructions (Energy mode)

A)

LASER OFF

Press the button  once, to turn the Flash on.

Press the button  once, to reset the Flash and start a new measure.

B)

LASER ON

Pulse

Turn on the laser beam and allow the FLASH to be exposed to a single pulse

C)

LASER OFF

Turn off the laser beam and read the energy measurement on the FLASH

307J

1.4 Replacing the batteries

When the low battery indicator () appears on the LCD you can still take around 300 measurements with the Flash power meter.

To replace the 2 x AA batteries that power the Flash unscrew the 4 Phillips screws on the back of the monitor and open up the casing.



Figure 1 : Batteries compartment

1.4 Flash series specifications

1.4.1 Power mode

Parameter	² FLASH-500-55	FLASH-3K-55	FLASH-6K-55	FLASH-10K-55
Spectral range	0.19-20 μm			
Power Range	0.1 - 500 W	5 - 3000 W	20 – 6000 W	30 – 10 000 W
Maximum Average Power Density- 1064nm CW At 100 W average power At 500 W average power At 3000 W average power At 6000 W average power At 10000 W average power	25 KW/cm ² 5.0 KW/cm ²	7.0 KW/cm ² 5.0 KW/cm ²	8.0 KW/cm ² 7.0 KW/cm ²	7.0 KW/cm ² 5.5 KW/cm ²
Display Numerical Resolution	0.1W	1W	1W	1W ¹
Measurement Accuracy	± 3%	± 5%	± 5%	± 5%
Noise Equivalent Power (NEP)	0.1W	5W	20W	30W
Maximum Allowable Absorber Temp.	65°C	65°C	75°C	75°C
Battery	2 x AA			
Battery Life	5000 measurements			
Operating Temperature range	10 to 40 °C < 80% Relative humidity			
Storage Temperature range	10 to 60 °C < 90% Relative humidity			
Response time	5 s	10 s	5 s	5 s
Maximum Laser Beam Diameter	Ø 55 mm			
Maximum number of readings before probe must be cooled [for 25°C starting temp.]	100W 25 200W 12 300W 8 500W 5	0.5KW 6 1KW 3 1.5KW 2 3KW 1	1KW 6 2KW 3 3KW 2 6KW 1	1KW 10 2KW 5 5KW 2 10KW 1
Maximum exposure time before probe must be cooled to 25°C [for 25°C starting temp.] (This is the total time for all the readings)	100W 200s 200W 100s 300W 60s 500W 40s	0.5KW 72s 1KW 36s 1.5KW 24s 3KW 12s	1KW 36s 2KW 18s 3KW 12s 6KW 6s	1KW 60s 2KW 30s 5KW 12s 10KW 6s
Weight [g]	930	1240	1520	2150
Dimensions [mm]	88X35X335	88X45X335	88X36X335	88X46X335

Specifications are subject to change without notice.

¹ Over 10KW the numerical resolution is 0.1KW

² The FLASH-500-10S/20R5-IPL and the FLASH-500-55-W-IPL have the same specifications that the FLASH-500-55 except for the measurement accuracy. For these instruments typical power sensitivity is used.

1.4.2 Energy mode

See power mode specifications for operating and storage temperature ranges.

Parameter		FLASH-500-10S/20R5-IPL	¹ FLASH-500-55-W-IPL
Optical aperture	cm ²	1	23.76
	mm	10S : 10X10mm 20R5 : 20X5mm	Ø 55mm
Typical sensitivity	mV/J	0.013	
Typical Power sensitivity / Typical Energy sensitivity	J/W	5	
Response Time	s	2	
Minimum repetition period	s	15	
Maximum pulse width	ms	433	
Energy range (For 1.064µm ; 10ms pulse)	J	2 - 350	
Maximum Average Power Density-1064nm CW @ 10W	KW/cm ²	45	
Pulsed Laser Damage Thresholds (10ms)	J/cm ²	175	
Noise equivalent energy	mJ	500	
Accuracy	%	± 5	

¹ The FLASH-500-55 has the same specifications that the FLASH-500-55-W-IPL except for the accuracy.

For the Flash-500-55, FLASH-3K-55, FLASH-6K-55 and FLASH-10K-55 typical energy sensitivity is used.

Energy calibration is available on special request for any Flash model.

2 OPERATING INSTRUCTIONS

Laser power detection is completely automatic. There is no need for an external timer.







WARNING:





WHEN "HOT" APPEAR ON THE SCREEN TURN OFF THE LASER BEAM IMMEDIATELY TO PREVENT DAMAGING THE DETECTOR

Be careful not to exceed the maximum levels and densities stated in the specifications.

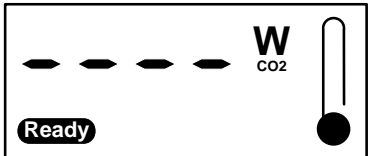
The handle on the flash is for carrying purposes only. It is not recommended for the user to hold the Flash during measurements. Extreme caution must be taken during laser power measurement.

Gentec-EO is not responsible for any damage or injury caused by misuse.

2.1 Activation of the device and measuring the power of a laser	
<p>(1) Place the FLASH on the measurement surface.</p>	
<p>(2) Press the button  once, to turn the FLASH on.</p> <p>→ State 2.1 : The FLASH turns on and does a lamp test (all segments of the LCD, the backlight and the 2 LEDs are ON).</p> <p>→ State 2.2 : Displays the software revision number. The 2 LEDs and backlight are OFF.</p> <p>→ State 2.3 : Displays the last measurement taken. The 2 LEDs and backlight are still OFF.</p> <p>If you hold the button  during the startup, the FLASH will display the software revision number until the button is released.</p> <p>It is recommended to leave the FLASH stabilize for 30 seconds after startup before starting a new measure.</p> <p><u>Do not turn the FLASH on with the laser on.</u></p>	<p>State 2.1</p>  <p>State 2.2</p>  <p>State 2.3</p> 
<p>(3) Press the button  once, to reset the FLASH and start a new measure.</p> <p>The FLASH displays the icon « Ready » and « ---- » waiting to detect an increase in temperature (the laser signal). The 2 LEDs are OFF.</p> <p>Note : The only way to exit this mode is to make a measure or to</p>	

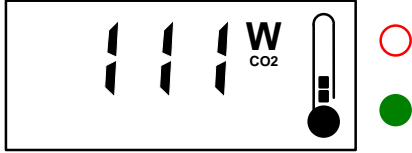
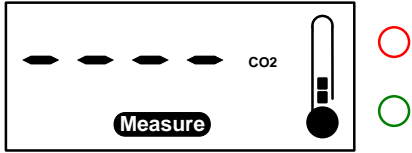

<p>shut down the device (see step (6)).</p> <p>(4) When the FLASH detects an increase in temperature (the laser signal), it automatically starts the measure, displays the icon « Measure » and a countdown of the number of seconds remaining to complete the measurement. The 2 LEDs are OFF.</p> <p>The countdown is 5 seconds for the FLASH-500, the FLASH-6K, the FLASH-10K and 10 seconds for the FLASH-3K. The thermometer is continuously updated independently of the mode.</p>	
<p>(5) As soon as the measurement is completed, the FLASH displays the measured value and turns the backlight and the green LED ON for 10 seconds.</p> <p>Immediately after the measured value is displayed, the laser beam can be turned off.</p> <p>The red LED will be ON instead of the green LED if a measurement error occurred. (See the error section for details). When the green LED is off, the next measurement can be done by returning to step (3) described above. The value is kept on display until a new measurement is started. (The last measurement is stored in the FLASH's nonvolatile memory).</p>	
<p>(6) To turn the FLASH off, press and hold the button  for 3 seconds. The FLASH temporarily displays « OFF » and turns off completely.</p> <p>The FLASH turns off automatically after 5 minutes of inactivity.</p>	

2.2 Semi-continuous mode (Does not work in energy mode [Joule])

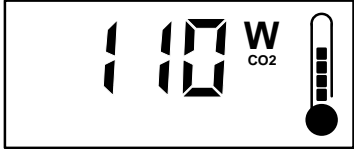



<p>The semi-continuous mode allows no stabilization time between two measurements.</p> <p>The semi-continuous mode can be used only after a measurement if the laser beam is still on and the max temperature is not reached. The semi-continuous mode is disabled when the FLASH is in error case (see section 2.6).</p> <p>State 1 : Do a first measure with standard mode as described above and let the laser ON.</p> <p>State 2 : Press the button  to do a fast measurement. (No countdown)</p> <p>State 3 : The second measure (semi-continuous mode) is</p>	<p>State 1</p>  <p>State 2</p> 
---	---









<p>then displayed.</p>	<p>State 3</p> 
------------------------	--

2.3 Wavelength selection (CO2 / YAG / Other)

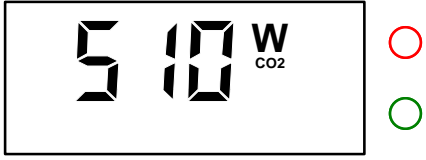
<p>The default wavelength is YAG. If there is a calibration at another wavelength, the default wavelength is the calibrated one.</p> <p>To change the wavelength, press and hold the button  for 3 seconds. After 3 seconds, the FLASH displays the text « Prog » and changes the active wavelength to the next one (Other). The new wavelength (CO2 / YAG / Other) flashes for 3 seconds, then the device returns to the normal display (last measure).</p> <p>To select the 3rd wavelength available (CO2), you must repeat the same procedure (long press of 3 seconds...). The new selection is stored in the FLASH's nonvolatile memory. Note: The wavelength selection function is not available when the FLASH is in "Ready" or "Measure" mode.</p>	 
--	--



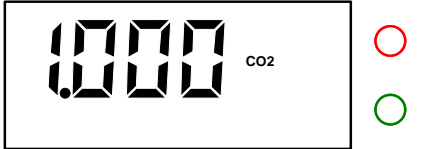

2.4 User's self calibration (see Appendix A for typical wavelength correction factors)

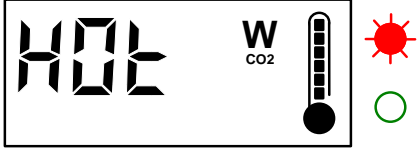
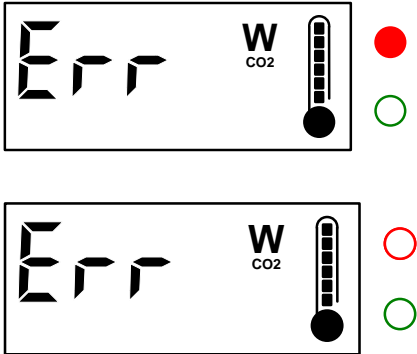
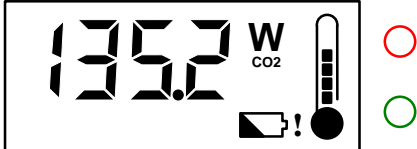

<p>Wavelength selection (section 2.3) shall be performed first to select the appropriate wavelength mode (CO2 / YAG / Other).</p> <p>(1) To adjust the sensitivity of the FLASH, first take a measurement as described above.</p> <p>Note: The self calibration is not available when the FLASH is in "Ready" or "Measure" mode.</p>	
<p>(2) When the measurement is completed, press and hold simultaneously the 2 buttons  and  for 3 seconds to enter the self calibration mode.</p> <p>→ State 2.1 : The FLASH displays the text « CAL » for 1 second.</p> <p>→ State 2.2 : Then it displays the correction factor for 1 second.</p>	<p>State 2.1</p>  <p>State 2.2</p> 

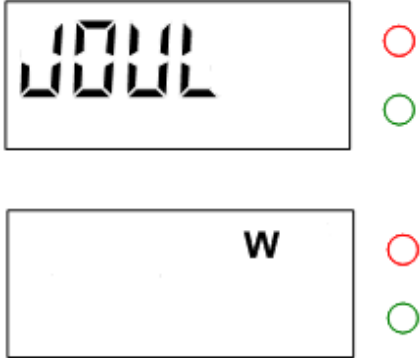
<p>The correction factor's default value is 1.000 for the 3 modes (CO2 / YAG / Other). Factory calibration also sets the correction factor for the newly calibrated wavelength to 1.000.</p>	
<p>(3) The FLASH then displays the value in watts of the last measurement. Press the  button to decrease the displayed value or the  button to increase it, until the desired value is reached.</p> <p>Each time you press the button the correction factor increases or decreases by 0.001 (0.1% of the full scale). The adjustment range is from -25% to +25%. Pressing for more than 1 second on either of the 2 keys is a typematic (a fast increase or decrease). After 3 seconds of inactivity, the FLASH alternates the displayed values between the correction factor and the new value of the last measure in watts. The self calibration can be made with either the correction factor or the power of the last measurement in watts.</p>	
<p>(4) To save the adjusted correction factor and exit the calibration mode, press and hold the 2 buttons  and  simultaneously for 3 seconds. The text « SAVE » will be displayed for 1 second before exiting the calibration mode.</p> <p>After 10 seconds of inactivity the device exits the self calibration mode automatically, without saving the changes.</p>	 
<p>(5) To return to the factory calibrated value, the user must enter the self calibration mode and set the correction factor to 1.000.</p>	
<p>2.5 LCD backlight</p>	
<p>To light up the backlight, press the button  (once). Pressing the button again will turn off the backlight (toggle mode).</p> <p>The backlight automatically turns off after 30 seconds.</p>	

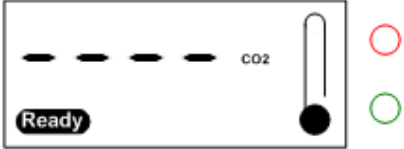
2.6 Error Cases	
<p>Error “Too hot” :</p> <p>The FLASH continuously checks the power meter head’s temperature. If the temperature exceeds the specification (65°C or 75°C), the graphic bar of the thermometer will be full, the red LED will blink and the FLASH will alternately display « HOT » and the lastest measurement. No further measurement is permitted as long as the device is in this error state. To exit this error, let the power meter head cool down.</p> <p>Turning off the device, does not remove the error state.</p> <p><u>Do not immerse the detector head’s in water</u> <u>(see page II : Warranty)</u></p>	
<p>Error “Over range” :</p> <p>If the FLASH is used to measure a power more that 5% over its maximum range, or if the maximum temperature (65°C or 75°C) is reached during the measure, « Err » will appear. Accordingly, the display will alternate between « Err » and « Hot » if the temperature exceeds (65°C). Also the red LED will light up instead of the green LED at the end of the measurement.</p> <p>The last valid measure is kept in nonvolatile memory until a new valid one is taken. To exit this error, perform a new measurement or turn off the FLASH and turn it back on.. The head of the FLASH must also cool down if the maximum temperature has been reached.</p>	
<p>Error “Low Bat” :</p> <p>When the battery voltage is too low, the « Low Bat » icon (🔋!) appears.</p> <p>See section 1.3 of this manuel to replace the batteries.</p>	

2.7 Displays over 10000 W (Only for the FLASH-10K)	
<p>In the special case of the FLASH-10K over 10000 W, the display changes for the Kilowatts instead of the watts (The maximum of the display is 12.0KW) .</p> <p>Exemple : The image at the right is 10.0KW and not 10.0W.</p>	

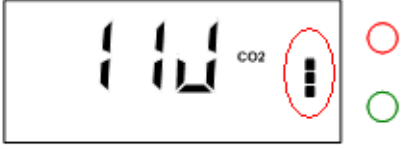
2.8 Using the FLASH in energy mode	
<p>(1) To change the mode from power to energy or to energy to power, first turn the FLASH off, Then turn the FLASH on by pressing and holding the two buttons.</p> <p>If the initial mode was power the FLASH displays « JOUL » and changes its status for the energy mode.</p> <p>If the initial mode was energy the FLASH displays « W » and changes its status for the power mode.</p> <p>The mode of the FLASH will stay the same as long as the procedure described above is not executed.</p>	
<p>(2) Place the FLASH on the measurement surface.</p> <p>It is recommended to leave the FLASH stabilize for 30 seconds after startup before starting a new measure.</p> <p><u>Do not turn the FLASH on with the laser on.</u></p>	
<p>(3) Press the button  once to reset the FLASH and start a new measure.</p> <p>The FLASH displays the icon « Ready » and « ---- » waiting to detect an increase in temperature (the laser signal). The 2 LEDs are OFF.</p> <p>Note : The only way to exit this mode is to make a measure or to shut down the device (see step (6)).</p>	
<p>(4) When the FLASH detects an increase in temperature (the laser pulse), it automatically starts the measure, displays the icon « Measure » and a countdown of the number of seconds remaining to complete the measurement. The 2 LEDs are OFF.</p> <p>The countdown is 2 seconds for the all the Flash-500. The thermometer is continuously updated independently of the mode.</p>	

<p>(5) As soon as the measurement is completed, the FLASH displays the measured value and turns the backlight and the green LED ON for 10 seconds.</p> <p>The red LED will be ON instead of the green LED if a measurement error occurred. (See the error section for details).</p>	
<p>When the progress bar at the right of the screen is gone, the next measurement can be done by returning to step (3) described above.</p> <p>The value is kept on display until a new measurement is started. (The last measurement is stored in the FLASH's nonvolatile memory).</p> <p>The progress bar indicates the time left of the 15 seconds rest time of the detector. It is not possible to start another measurement in until the countdown is over.</p>	
<p>(6) To turn the FLASH off, press and hold the button  for 3 seconds. The Flash temporarily displays « OFF » and turns off completely.</p> <p>The FLASH turns off automatically after 5 minutes of inactivity.</p>	

2 GENERAL INFORMATION

2.1 General instructions

To ensure a long lifetime of accurate measurements, the FLASH powermeter should be maintained within the following ambient conditions:

Storage environment temperature: 10 to 60°C, RH < 90%

Operating environment temperature: 10 to 40°C, RH < 80%.

It is possible to store and operate your Gentec-EO FLASH powermeter beyond this range. For any specific requirements, please contact your local Gentec-EO representative.

For the most accurate measurements, center the beam on the sensor face. The beam diameter on the sensor should ideally be the same size as the beam diameter of the original calibration, which corresponds to >98% encircled power centered on 50% of the sensor's surface (this complies with the International Electrotechnical Commission standard #1040: "Power and Energy Measuring Detector..."). Refer to the calibration certificate for the exact calibration beam diameter.

2.2 Safety operation notes

Diffusive surfaces : When using the FLASH be aware of the diffused back reflection ~ 5-15%.

Specular surfaces : When using the FLASH with the windows “W” option be aware of the diffused back reflection ~ 8-10%.

As on any diffusive surface, the light on the sensor coating is scattered more or less uniformly as a Lambertian diffuser. It is recommended to use the head with a black protective sleeve to limit wide-angled diffused reflections.

Safety laser glasses recommended.

Detector temperature while in operation: During usage, the detector head can become hot enough to cause burns.

2.3 Damage to the optical absorber material

Damage to the optical absorber material is usually caused by exceeding the manufacturer's specified maximum incident **average power density**. Refer to the specifications from section 1.4 of this manual.

The FLASH series can measure up to 10kW. The beam diameter should always be as large as possible to avoid damage to the absorber. **We recommend between 70% and 90% of the nominal head aperture,** e.g. 4.6-5.2 cm in diameter for both Flash power meters.

In any case, the beam's incident area should not be less than 10% of the detector's aperture. Please contact Gentec-EO to make measurements with such smaller beams.

The damage threshold is decreasing with the laser beam power. The following table calculates the diameter corresponding to the damage threshold for a Gaussian beam profile. The “minimum 1/e² beam diameter” is calculated to obtain a peak intensity 50% lower than the damage threshold and should be considered as the “safe” minimum diameter. If there are “hot spots” in the beam profile, they must be considered in the calculation of the peak intensity.

Laser Beam Power [kW]	FLASH-500-55			FLASH-3K-55		
	Damage Threshold ¹ [kW/cm ²]	Damage 1/e ² Beam Diam. ^{2,3} [cm]	Min. 1/e ² Beam Diam. ^{2,3,4} [cm]	Damage Threshold ¹ [kW/cm ²]	Damage 1/e ² Beam Diam. ^{2,3} [cm]	Min. 1/e ² Beam Diam. ^{2,3,4} [cm]
0.1	25	0.1	0.2			
0.5	5	0.5	0.8	7.0	0.6	0.9
1				6.5	0.7	1.0
2				5.7	1.0	1.4
3				5.0	1.3	1.9
	FLASH-6K-55			FLASH-10K-55		
3	8.0	1.3	1.9			
6	7.0	1.9	2.6	7.0	1.9	2.6
10				5.5	2.6	3.3

¹ Peak Intensity.

² For Gaussian beam profile, the peak intensity is twice the beam power.

³ Diameter of a circle corresponding to 86% of the entire beam power.

⁴ Including a security factor of 50%

Damage may also be caused if you use a detector with a contaminated absorber surface. Slight discoloration of the coating may occur, but this does not affect the calibration.

In the event of major damage to the coating, the FLASH Series sensors can be recoated. Contact your local Gentec-EO representative for information on repair and recalibration. See p. // Contacting Gentec Electro-Optics Inc.

DECLARATION OF CONFORMITY

Application of Council Directive(s): 2004/108/EC EMC Directive



Manufacturer's Name: Gentec Electro Optics, Inc.
 Manufacturer's Address: 445 St-Jean Baptiste, suite 160
 Québec, QC, Canada G2E 5N7

European Representative Name: Laser Components S.A.S.
 Representative's Address: 45 bis Route des Gardes
 92190 Meudon (France)

Type of Equipment: Laser Power Meter
 Model No.: FLASH
 Year of test & manufacture: 2010

Standard(s) to which Conformity is declared:
 EN 61326-1:2006

Standard	Description	Performance Criteria
CISPR 11	Limits and methods of measurement of radio interference characteristics of information technology equipment. Testing and measurements of radiated emission.	Class B
EN 61000-4-2	Electromagnetic compatibility (EMC) – Part 4: Testing and measurements techniques- Section 4.2: Electrostatic discharge.	Class A
EN 61000-4-3	Electromagnetic compatibility (EMC) – Part 4: Testing and measurements techniques- Section 3: Radiated, Radio Frequency immunity.	Class A
ENV 50204	Radiated Electromagnetic field from digital radio telephones- immunity test 900MHz pulsed	Class A

I, the undersigned, hereby declare that the equipment specified above conforms to the above Directive(s) and Standard(s).

Place: Québec (Québec)

Date : January 7, 2010

(President)

Appendix A: Typical wavelength correction

Typical wavelength correction
Spectral Absorption Plot measured for FLASH series Power Detector

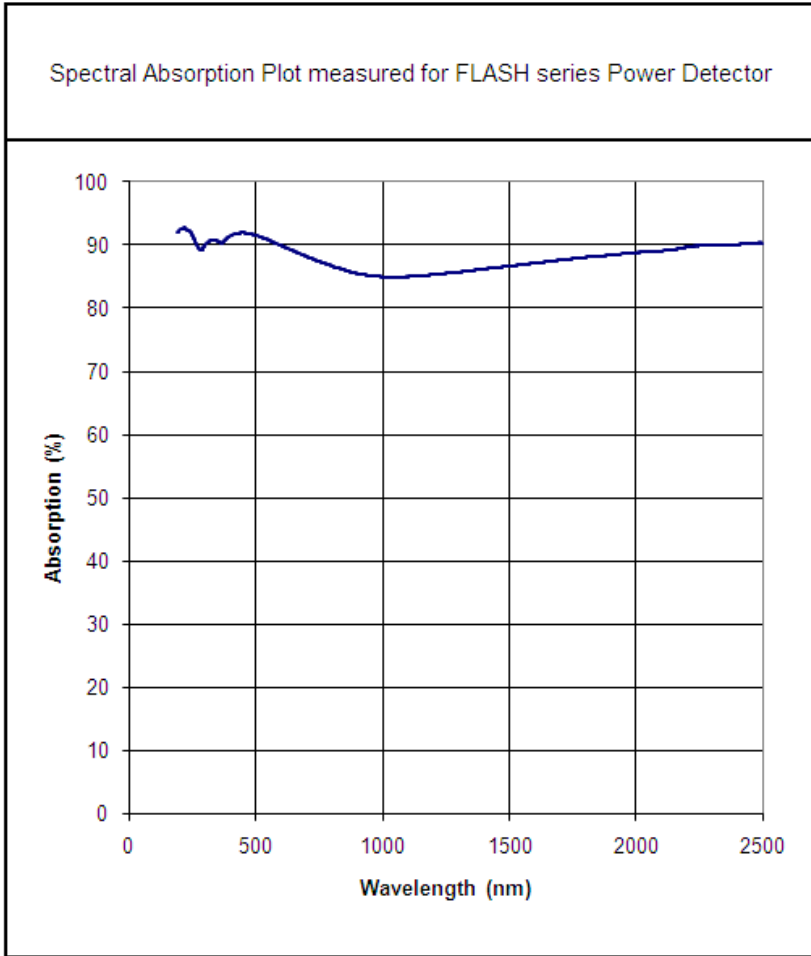

Wavelength Correction Factor for "Other"	
Wavelength (nm)	Correction Factor multiplier
193	0.922
213	0.917
248	0.926
266	0.942
308	0.940
337	0.936
355	0.938
488	0.926
514	0.930
532	0.933
578	0.941
632	0.950
694	0.962
720	0.967
810	0.982
980	0.999
1064 *	1.000 "or select YAG"
1550	0.978
2100	0.953
10600	0.930 "or select CO2"
* Calibration wavelength	
The correction factors are valid only when the "Other" wavelength is selected.	
Adjustment factors are not NIST traceable	
See section 2.3 Selection of wavelength	
See section 2.4 User's self calibration	

The typical wavelength correction is valid with the standard calibration only. For custom product refer to the certificate of calibration.

Appendix B: Optional Flash Stand

The following figure show how the stand should be assemble.

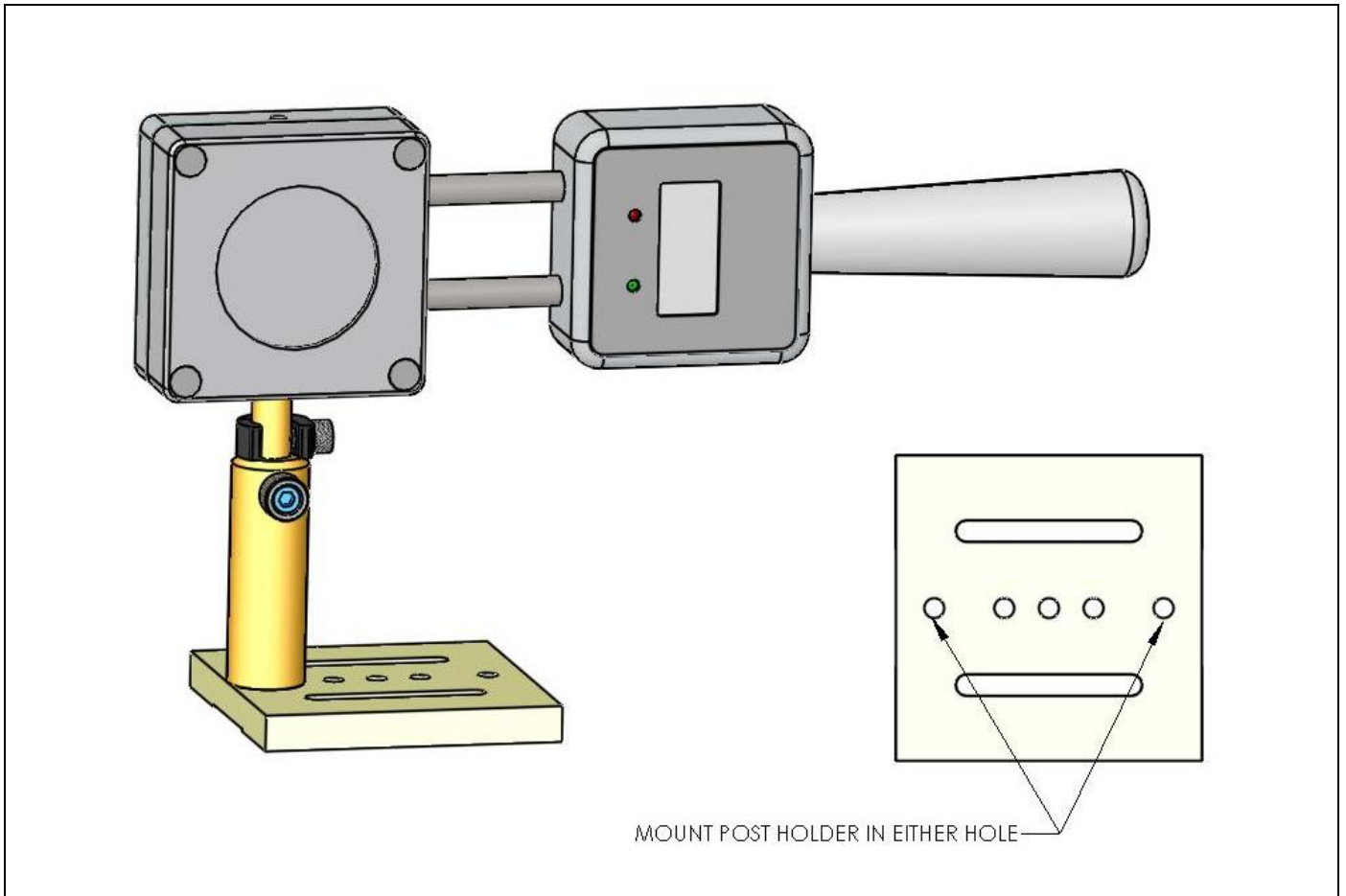

Appendix C: WEEE directive**- Recycling and separation procedure for WEEE directive 2002/96/EC:**

This section is used by the recycling center when the detector reaches the end of its life. Removing the insulation or troubling the inside of the monitor will void the detector warranty.

The complete Detector contains:

- 1 Detector
- 1 instruction manual
- 1 calibration certificate

- Separation:

Paper : Manual and certificate

Printed circuit board:

inside the Detector,

Aluminum: Detector casing.

Plastic: parts inside the Detector.

GENTEC-EO
WORLDWIDE



LEADER IN
LASER BEAM
MEASUREMENT
SINCE 1972

CANADA

445 St-Jean-Baptiste, Suite 160
Quebec, QC, G2E 5N7, Canada

T (418) 651-8003

F (418) 651-1174

1 (888) 5GENTEC (Canada and USA only)
service@gentec-eo.com

UNITED STATES

5825 Jean Road Center
Lake Oswego, OR, 97035, USA

T (503) 697-1870

F (503) 697-0633

1 (888) 5GENTEC (Canada and USA only)
service@gentec-eo.com

Calibration Centers

445 St-Jean-Baptiste, Suite 160
Quebec, QC, G2E 5N7, Canada

Werner von Siemens Str. 15
82140 Olching, Germany