

USER MANUAL

M2DU

M2 Stage for Beamage Series



User Guide

Beamage + M2DU M² system

Applies to: Software Ver. 6.00S1c or higher, running under Windows XP with SP2 or higher or Windows Vista.

Very Important: With full Administrator Rights, Install, Open and Close the latest Software before connecting the Camera or the Stage.

Short of time? Save yourself time by carefully following this User Guide the first time. Done properly once, the next time will be simple and fast.

For future convenience, copy your lens setup details from page 7 in the table below.

Focal Length	You measure: LD	Add	Enter in dialog: LPPSO	Enter in dialog: ZoDelta

Applications

- M² measurement of CW & pulsed lasers
- M² measurement of focused beams
- Focus position of laser assemblies

Features

- **ASR™ Auto Scan Range** for ISO compliant scan
- USB 2.0 for field service applications
- Fast, Compact, Portable system
L x W x H: 8 x 2.9 x 4.3" (200 x 109 x 74 mm)
Total weight 4 lb, (1.8 kg)
- Field-replaceable lens options

Contents

Contents	Page
1) Description	2
2) Beam Modeling for Lens Selection	3
3) Parts List	4
4) Getting Started	5
5) Assemble the unit	6
6) Laser Safety	7
7) Preset the Attenuation level correctly	7
8) Start the Software	7
9) Align the Beam	9
10) Check Exposure and Subtract Noise	9
11) Set the Capture Block	9
12) Perform a Coarse Scan	11
13) Perform a Final Scan	11
14) Source Beam Characteristics	12
15) Save the data	12
16) Second time round	13
17) Support	13

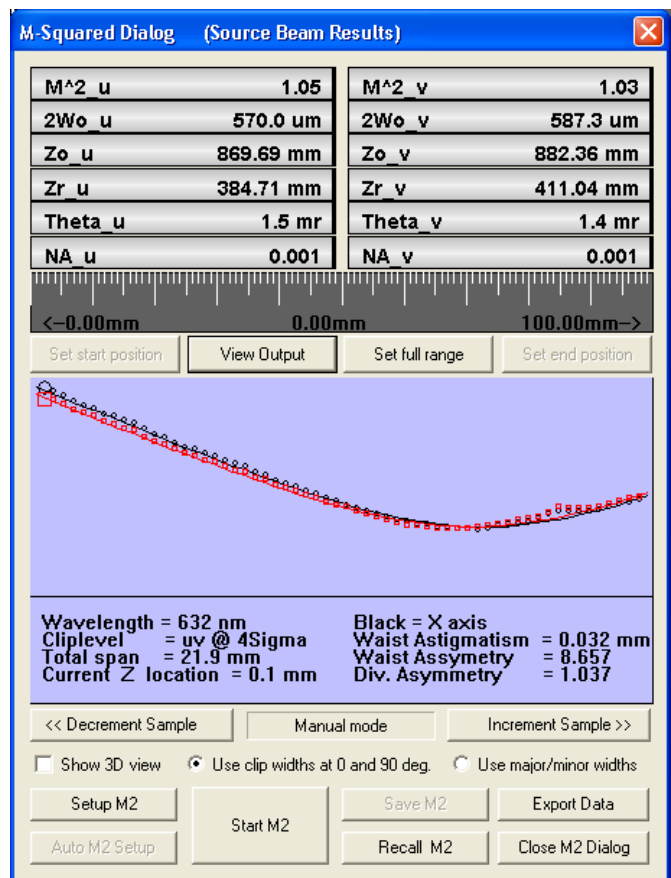

1) Description

The USB 2.0 **M2DU** accessory converts Beamage beam profiling cameras into a compact fully ISO 11146 compliant, M² measurement system.

The **M2DU** system comprises a lens fixed to the front of a 42.5 mm travel stage on which the Beamage is carried.

An achromat refocuses an input beam to a waist within the stage travel range. The standard is 100 mm focal length. Alternative lens focal lengths and coatings will be recommended/supplied for some lasers.

ASR™ auto-sampling measures the hyperbolic region about the waist and at z_R>2 in accordance with the ISO standard. A least squares hyperbolic fit to the second moment diameter data allows calculation of the M² value and related parameters for both the focused beam and the source beam.



M² Beam Quality Factor - Explained

M², or Beam Quality Factor, is a dimensionless parameter that characterizes the degree of imperfection of a real-world laser beam. The closer the M² value is to 1.0, - i.e. the closer the beam is to TEM₀₀ Gaussian perfection - the closer the beam can be focused to its diffraction limited spot size.

Due to limitations of the optical cavity, the lasing medium, and/or the output/ancillary optics, most beams are not the 'perfect', diffraction-limited, Gaussian profile, pure TEM₀₀ mode described in textbooks. Complex beams can contain multiple TEM_{xy} contributions leading to high values of M².

At its simplest M² may be defined as: *The ratio of the divergence of the actual beam, to that of a theoretical, diffraction-limited TEM₀₀ beam with the same waist diameter.*

Θ = The measured, far-field, full-angle divergence of the actual beam

θ = The theoretical far-field divergence of a 'perfect' TEM₀₀ Gaussian beam which has the same waist diameter as the measured beam.

Where: 2W₀ = The second moment (4σ) beam waist diameter.

$$M^2 = \frac{\Theta}{\theta}$$

$$\theta = \frac{2\lambda}{\pi W_0}$$

The shape of the M² curve may be shown to be hyperbolic of the form:

$$2W(z) = 2W_0 \sqrt{1 + \left(\frac{z}{z_R}\right)^2}$$

Where z_R is the Rayleigh Range, defined as the distance at which the beam diameter is √2 greater than the diameter at the waist. z_R may be shown to be:

$$z_R = \frac{2W_0}{\Theta} = \frac{\pi W_0^2}{M^2 \lambda}$$

A definition of M² in terms of a measured diameter is:

$$M^2 = \left(\frac{\pi}{4\lambda}\right) \cdot \Theta \cdot 2W_0$$

Specifications

- **Max. beam diams.:** See graph right.
- **400 to 800 nm** with standard lens
- **260 to 1150 nm** with optional lenses
- To **1350 nm** on high power beams with optional lenses
- **M² Range*** 1 to >50
- **M² Accuracy*** ± 5% typical
- **M² Repeatability*** ± 2% typical

* Beam dependent. Achieving absolute accuracy better than ± 5 % is possible, but can be difficult.

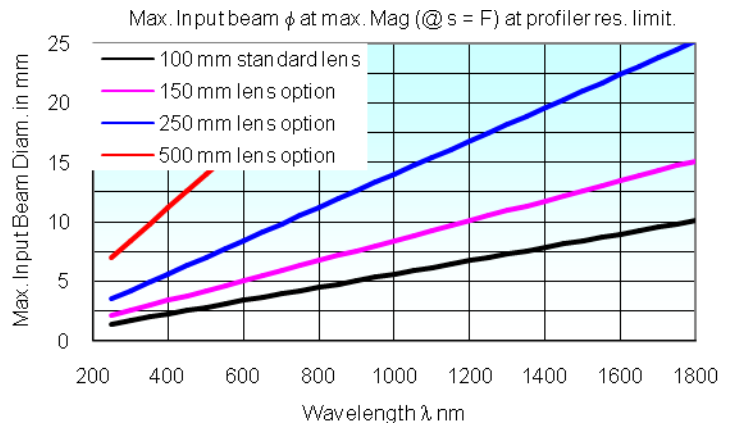

2) Parts List

- The recommended default camera is the **Beamage CCD12**.
- **M2DU-WC-XXX-XXX** system comprising the following options:

Standard System Options e.g. **M2DU-WC-250-NIR**

	Lens focal length options	Wavelength options
M2DU-WC Comprising: USB 2.0 M2DU Stage 2.5 μm steps, 44 mm travel 3 m flexible cable Lens mount bracket Mounted lens Power brick	-100 100 mm focal length 22 mm aperture	
	-150 150 mm focal length 22 mm aperture	-VIS Achromat for 400-800 nm -NIR Achromat for 630-1100 nm
	-250 250 mm focal length 22 mm aperture	

3) Getting Started

Short of time? Save yourself time by carefully following through this User Manual the first time that you use the equipment.

This User Guide assumes that the Beamage system is installed, has been run with the Version 6.00R12i or higher software in the PC you are to use, is working in your PC, and that you have already learned how to use the Beamage in standard operation on beams from this laser. If this is not the case, first install the software, install and run the Beamage, and understand its operation before working with the M2DU stage.

IMPORTANT: You will require Windows XP with SP2 or Windows Vista, **with ≥ 1 GB of RAM** for Beamage with the M2DU. If you only have 512 MB of RAM, then with this multiple image based measurement system you will probably find that your computer slows significantly, even freezes, and there is nothing that we can do to help you.

A minimum screen size of 1024 x 768 pixels is required. Recommended is 1280 x 1024 or higher.

Windows Support. *We no longer support Windows 2000.* If you see problems in Windows 2000 which we do not see in XP, then we will not put effort into curing them; we will simply recommend that you move to XP or Vista.

If you do not have an M2DU stage and wish to perform an M^2 measurement using a different stage, manual or automatic, request a separate User Manual entitled: Beamage Manual Z Entry M^2 .

Applicable Standard. ISO 11146 is the applicable standard: 'Test methods for laser beam parameters: Beam widths, divergence angle, and beam propagation factor.'

It requires:

- Use of the Second Moment (4σ or Variance) definition of the beam diameter.
- Averaging of 5 samples at each position in z.
- A minimum of ten samples in z. '... half of them shall be distributed within one Rayleigh length on either side of the beam waist and half of them should be distributed beyond two Rayleigh lengths from the beam waist.' (Gentec-eo offers from 10 to 60 samples in z).

For equispaced samples in z, this requirement of the standard is met by a minimum of 12 samples at $zR/2$ spacing from $-2.5 zR$ to $+ 3zR$. (For equispaced samples, the samples in the ± 1 to $1.5 \times zR$ region are superfluous to the requirements of the Standard, but may still be used in the calculation.)

The beam diameter is: $2.W_0$ at the beam waist

1.414 greater, = $2.83.W_0$, at $\pm 1 zR$ (Rayleigh Ranges or 'length')

2.236 greater, = $4.47.W_0$, at $\pm 2 zR$

2.692 greater, = $5.38.W_0$, at $\pm 2.5 zR$

3.162 greater, = $6.32.W_0$, at $\pm 3 zR$

ISO 11146 requirements can also be met by more samples at a higher sampling frequency.

- A least squares hyperbolic fit to the data.

Notes:

a) With a beam profile that is a pure Gaussian, the Variance (Second moment) definition is exactly the same as selecting a 13.5% Clip Level, but if your beam is non-Gaussian -which is most beams - the Variance method is more consistent. An exception to this general rule is that the presence of a significant background level above zero or background noise will skew the Variance reading to larger values.

b) In accordance with Section 6.2 of the ISO 11146 Standard, the Second Moment calculation integrates over 99% of the total energy in the profile. See Appendix B for Beam Diameter definitions.

c) If the beamwaist profile in the propagation direction - the z direction - is either too flat or too 'V' shaped, the fit will be poor.

d) With the lens provided the system will measure the M^2 of collimated lasers. If you already have an appropriate beamwaist and can position it within the range of travel of the stage, you can measure the M^2 of the beam directly.

4) Assemble the unit

The diagram shows the unit with an 85 mm lens. For longer focal length lenses the lens assembly moves to the left, in the diagram below. The measurement **LD** mm is required for the calculation of the original beam characteristics.

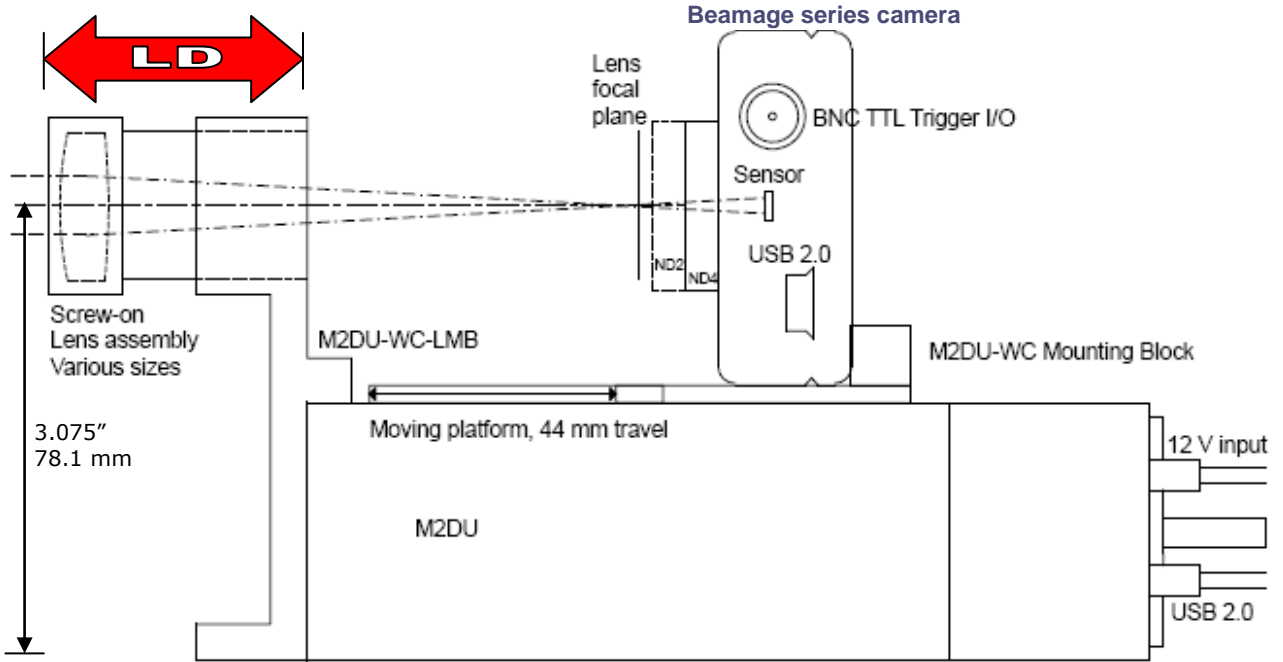

If ordered as a camera + M2DU system, you should receive the unit completely or partially preassembled. If not, assemble as follows. You will/should have been supplied with the following parts:

- **Beamage** series camera
- **M2DU-WC-XXXXXX** system comprising the following items:
 - o **ND2.0** additional ND filter to screw onto the ND4.0 provided with the camera.
 - o **M2DU** UMove™ USB 2.0 stage
 - o 3 m (10 ft) USB 2.0 cable (A to mini-B 5)
 - o **DRPSU 12-1.25-1** Power supply with US power cord
 - o **M2DU-WC** Mounting Block
 - o **M2DU-WC-LMB** Lens mount bracket
 - o **LNZ-XXX-YYY** Achromatic lens in holder plus spacers

For some applications/wavelengths a different **LNZ-XXX-YYY** will have been provided, where **XXX** is the focal length in mm and **YYY** is the coating wavelength range. This will come with one or more spacer tubes that set the lens at the correct distance.
 - o 8 pieces of #4-40 x 0.5" Philips panhead stainless steel black screws. (2 spares)
- Attach the **M2DU-WC** Mounting Block to the **rear** of moving block on the M2DU stage using two #4-40 x 0.5" screws.
- Attach the **Beamage** series camera to the **M2DU-WC** Mounting Block using two #4-40 x 0.5" screws.
- Attach the **M2DU-WC-LMB** lens mount bracket to the front of the **M2DU** stage using two #4-40 x 0.5" screws.
- Optional: Attach the **M2DU-WC-LMB** lens mount bracket to an optical table, breadboard or other hardware using two ¼"-20 x 0.5" screws (you supply). If your hardware is Metric use M6 x 12.5 mm caphead screws (you supply).

supply). To mount it higher, attach either through these holes or to the threaded holes in the base of the unit.
IMPORTANT: If you use the threaded base holes, screw length inside the unit must never exceed 0.375" (10 mm).

- Add the **LNZ-XXX-YYY** lens assembly. The standard lens provided is a 100 mm achromatic. If you use a longer focal length lens, use an appropriate additional spacer tube. These are provided by Gentec-eo when the longer focal length lens is provided with the system.
- Optionally, but recommended, use the lower slot in the Lens mounting bracket to bolt the whole assembly to an optical table or other rigid mount.
- Connect the 12 V **DRPSU 12-1.25-1** power supply to the **M2DU**. Connect a USB 2.0 cable between the **M2DU** and the PC. The **Found New Hardware USB Device** wizard will appear. Do not let it search on the web. Select **No, not this time**, then ask it to **Install the software automatically (Recommended)**. It should find and install the driver highlighted in this Device Manager screen.

5) Laser Safety The beam will suffer some back-reflection from lens surfaces and ND filters and from the housings if the beam is misaligned. **You are totally responsible for your own laser and eye safety and that of others in the vicinity. If you cannot accept this responsibility, proceed no further.**

6) Preset the Attenuation level correctly

Avoid destruction of your camera! If you did not already do so earlier, for the value of **2Wo"** from the curves in the Beamage manual (page 1-7 for CW, 1-8 for pulsed), determine whether you will need to add additional sampling/attenuation in order to avoid saturation of the camera at the focus. If so add as required before proceeding. An additional **ND2.0** filter is provided with the M2DU.

Chapter 5 of the Beamage manual describes attenuation and sampling solutions. Gentec-eo offers additional ND filters, variable ND filters, wedge samplers, & holographic beam samplers to assist you,

Verify the lens incident power with a power meter.

7) Start the Software

Start the software. Click the **M2** button. A series of warnings advise that the software will in turn:

- Set the Clip[a] level to 4sigma.
- Set Full resolution
- Turn off the filter
- Force the crosshairs to zero degrees

Accept all the offerings by clicking **OK**. You will then see the **Beamage M-squared Setup** box.

a) Enter Wavelength in nm and Lens Focal Length.

b) LPPSO: If you require that the software calculate the source beam characteristics, you need to measure a critical distance.

The flexible lens focal length, wavelength & spacer options means that lens Principal Plane to scan stage position is not fixed and must be entered.

Use a **mm** scale/tape to measure **LD**, the distance from the front of the lens flange (with dust cap removed) to the back of the Lens Mount Bracket - the red double arrow labeled **LD** on the diagram two pages earlier. This is a distance that is easy for you to measure. It must then be corrected for the distance between the front of the lens and its Principal Plane, and for the distance between the rear of the lens bracket and the sensor in the camera. Add this value to the value shown in the table below **for your lens** (see label on lens), and enter this

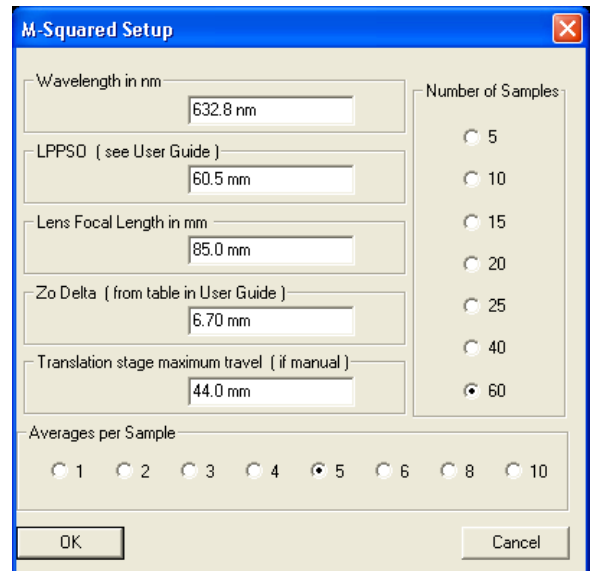
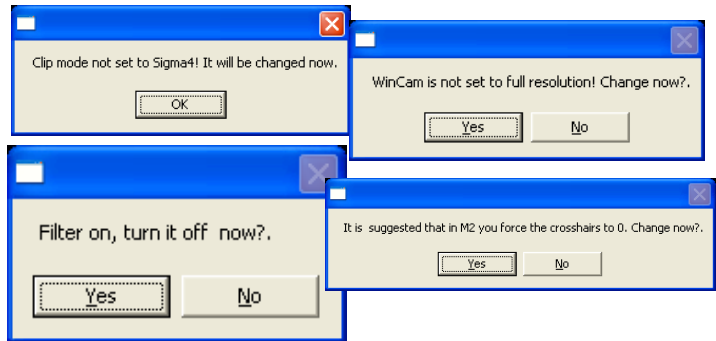

value in the **LPPSO** entry in the dialog. Enter the **Zo Delta** value *for your lens* in the dialog.

Lens LNZ - f mm - Diam.	LD (User measured) See diagram below	+(A-Zo Delta) See diagram below	=LPPSO (Enter in M2 dialog) Lens Principal Plane to Sensor at 0	Zo Delta (Enter in M2 dialog) Front of lens mount to Principal Plane
User's own lens?			=	
LNZ-75-UV		24.4	=	9.7
LNZ-75-VIS		26.1	=	8.0
LNZ-75-NIR		26.5	=	7.6
LNZ-75-TEL		21.5	=	2.0
LNZ-85-VIS (Legacy lens)	33.1 (Fixed)	27.4	= 60.5	6.7
LNZ-100-UV		24.0	=	10.1
LNZ-100-VIS		24.3	=	9.8
LNZ-100-NIR		24.3	=	9.8
LNZ-100-TEL		31.1	=	3.0
LNZ-150-UV		23.6	=	10.5
LNZ-150-VIS		25.3	=	8.8
LNZ-150-NIR		26.8	=	7.3
LNZ-150-TEL		30.8	=	3.3
LNZ-150-50-UV		23.6	=	10.5
LNZ-150-50-VIS		25.3	=	8.8
LNZ-150-50-NIR		26.8	=	7.3
LNZ-150-50-TEL		30.8	=	3.3
LNZ-250-UV		23.3	=	10.8
LNZ-250-VIS		24.7	=	9.4
LNZ-250-NIR		33.9	=	0.2
LNZ-250-TEL		36.1	=	-2.0
LNZ-250-50-UV		25.4	=	8.7
LNZ-250-50-VIS		24.8	=	9.3
LNZ-250-50-NIR		29.4	=	4.7
LNZ-250-50-TEL		37.0	=	-2.9
LNZ-300-NIR		31.4	=	2.7
LNZ-500-50-UV		24.4	=	9.7
LNZ-500-50-VIS		25.6	=	8.5
LNZ-500-50-NIR		24.4	=	9.7
LNZ-500-50-TEL		37.0	=	-2.9

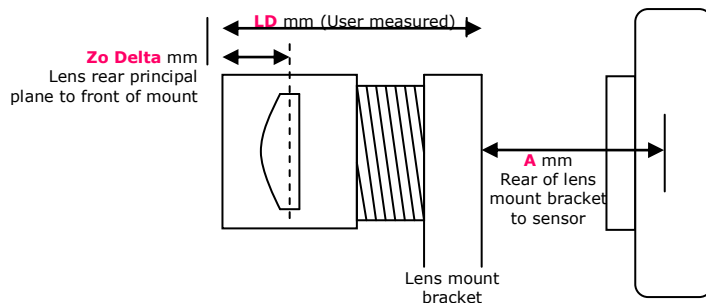

Zo Delta. Enter the value for your lens from the table above.

Translation Stage maximum travel is automatically read from the stage EEPROM when a stage is present.

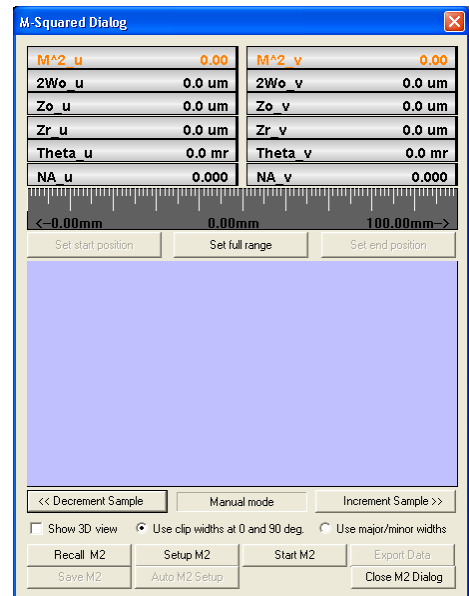

Click **OK**, and the **M Squared Dialog** shown right will appear.

8) Align the Beam

**** Correct alignment is critical to successful operation **** A misaligned beam can lead to astigmatism and to overestimation of the M^2 value. You are aiming for on-axis to $\sim\pm 2$ mm max.

The M2DU stage sets the optical axis at a height of 3.08" (78.2 mm) above the base.

The lens and camera covers have black on white beam target crosshairs with 5 and 10 mm circles. These are useful for visible lasers. The lens cameras have a central hole. For NIR and telecom lenses the lens cap includes a pink fluorescent phosphor on the cap. For the camera end you may require suitable wavelength imaging plates or viewers.

With these covers in place:

- Click on the right hand edge of the gray scale to move the stage to the end closest to the motor.
- Align the beam on the target on the front of the lens.
- Rotating about the front lens cap center as pivot point, adjust the laser or the rear of the M2DU to center the laser beam on the camera target.
- Lock down the laser and the M2DU stage.
- Remove the lens & camera covers. Open & Start the software.
- Verify that Peak ADC is <90 %. If not, revisit Sec. 4.

9) Check Exposure and Subtract Noise

Check Exposure. Move the stage in z by clicking on the scale until the beam diameter is at or close to minimum. **CW beams:** Adjust any attenuation/sampling until the **Peak ADC** is <95 % and that, at the beamwaist: **0.2 ms \leq Exposure time \leq 20 ms**. If it is not, revisit Section 4 above.

Pulsed laser beams: Currently the software averages multiple pulses and varying the Exposure time effectively varies the number of pulses averaged. The minimum PRR for which the system will work reliably in default mode is around 1000 Hz.

Ensure that at the beamwaist, both **(0.2 ms \leq & (10,000/PRR) ms) \leq Exposure time \leq 20 ms**. A later release may extend these limits.

[Setting the maximum exposure limit to 1,000 ms instead of 200 ms can extend the upper exposure limit to 200 ms, but the increase in dark current spikes will affect the M^2 accuracy.]

Subtract residual electronic noise. With the stage close to the focus:

- Right-click the **Exposure time** slider and uncheck **Enable auto exposure adjustment**.
- Set **Average** to **Average 10**.
- Block the beam and allow ≥ 10 frames to average.
- Click on the background subtraction button. Click OK.
- Recheck **Enable auto exposure adjustment**.

10) Set the Capture Block

In order to minimize the size of saved M2 files, it is recommended that you minimize the **Capture Block**. If you ignore this advice, your default M^2 file size will be ~ 135 MB and your hard drive fill rapidly.

By contrast, a 256 x 256 Capture Block reduces file size to ~ 8 MB.

Press **Alt S** to open the **Capture Setup** box. In the **M-Squared Dialog** box, click at the extreme ends of the gray scale and watch the image in the **Capture Setup** box.

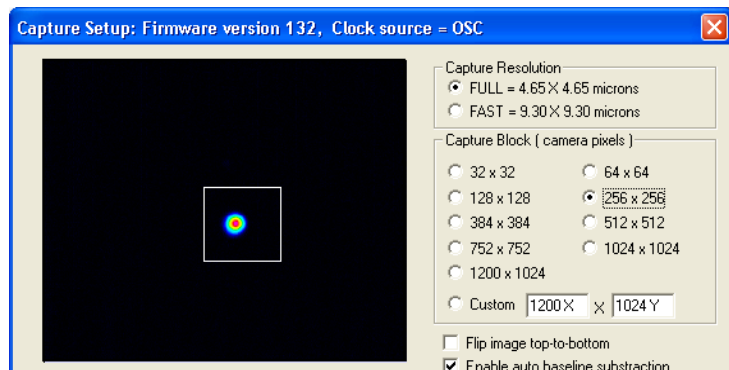

If the image moves a lot, readjust your beam alignment until it does not move much at all. With the stage at the lens end, select a **Capture Block** around five times the visible beam size. In most cases, 256 x 256 should suffice.

For CW lasers Auto-exposure sets correct exposure for all z values.

Once done, close the **Capture Setup** dialog and right-click on the 2D image area to open a box with several options.

- ✓ Inclusion region ENABLED
 - Lock current inclusion region
 - Inclusion region shape is round
 - Inclusion region shape is elliptical
 - Inclusion region shape is square
 - Inclusion region shape is rectangular
- ✓ Define inclusion region shape, size and orientation

Click **Define inclusion region shape, size and orientation**, and set up **Elliptical, Circular** and the **Automation** section as shown right. You may ignore the other boxes in the dialog.

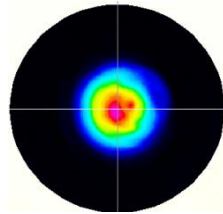

Inclusion Shape, Size and Orientation [X]

Inclusion Shape

Rectangular, Square

Elliptical, Circular

Set Clockwise Orientation of Major: 0 is Horiz

In Degrees

Dimensions

Major axis microns

Minor axis microns

Automation

Auto Orient

Width = Clip[a] diameter times

OK Refresh Cancel

11) Perform a Coarse Scan

Press **Auto M2 Setup** to perform a coarse scan of 20 equally spaced points in z using the full length of the stage, with an Average of 2 images per z position.

Orange Data. During the scan through a beamwaist, the software changes the Exposure to accommodate the change in the irradiance as the beam diameter changes. During Exposure iteration, before the correct Exposure is determined, the **Peak %** will sometimes go to 100% and the numbers will turn **Orange** to warn of this saturation. Do not worry. The software ignores these values and *only* uses data taken when the exposure has stabilized and the **Peak %** is below 100%.

At the conclusion of the scan, the software performs a hyperbolic weighted least squares fit to the data to calculate the approximate position of the beamwaist, **z0**, and the Rayleigh Range, **zR**.

Based on these values, the software produces estimates of the full results, but more importantly the **ASR™** Auto Scan Range software module sets upward pointing white tick marks on the scale at the suggested **Start** and **End** positions for an ISO 11146 compliant scan.

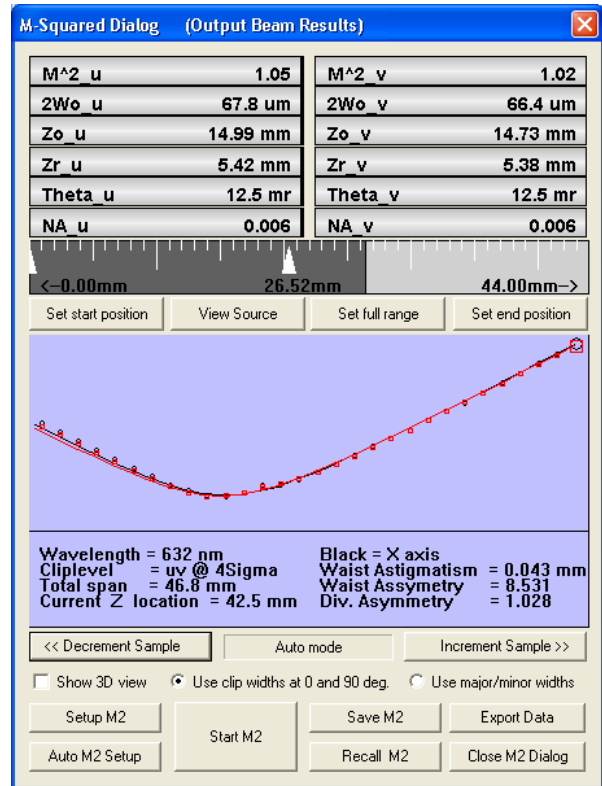

12) Perform a Final Scan

Unless you have reason to disagree with the proposed scan range, press Start M2.

The software automatically performs a scan of 60 equally spaced points in z over the set range, with an Average of 5 images per z position.

At the conclusion of the scan, the software performs a weighted least squares hyperbolic fit to the data to calculate the final results.

M²_{u,v} the M² values.

Remember the anticipated specifications:

- **M² Accuracy*** ± 5% typical
- **M² Repeatability*** ± 2% typical

* Beam dependent. Achieving absolute accuracy better than ±5 % is possible, but can be difficult.

If your beam M² is actually 1.03, the result that you see may vary from 0.98 to 1.08. If it is less than 1.0 it will show in orange, as **0.98**, but this does not necessarily mean that it is a bad result.

2Wo_{u,v} the beamwaist diameters.

Zo_{u,v} the beamwaist positions with respect to the principal plane of the lens.

Zr_{u,v} the beams Rayleigh range

Theta_{u,v} and **NA_{u,v}**; the far-field divergence of the focused beam in mrad and as NA.

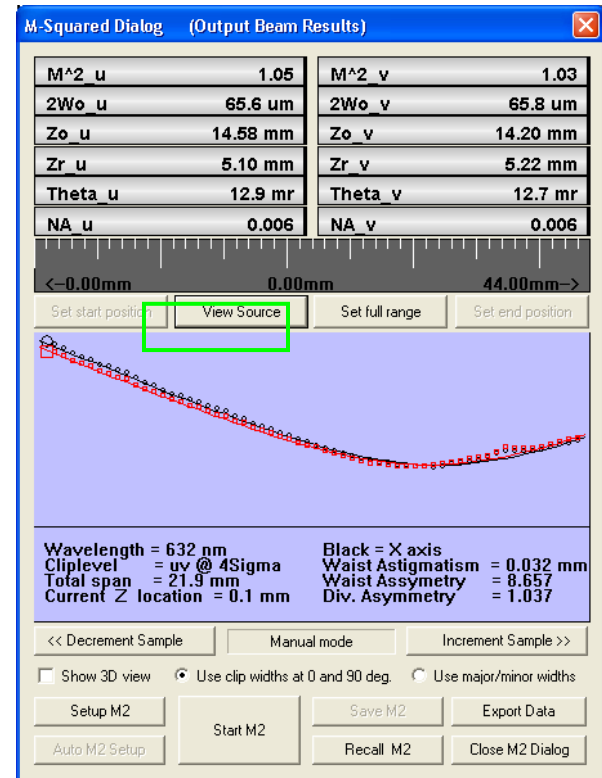

13) Source Beam Characteristics

Press the **View Source** button below the dialog to toggle between the **Output** beam and the source beam.

The software uses Gaussian beam calculations to calculate the position and dimensions of the source beam. Below the curve (see previous page) are calculations of:

$$\text{Waist Astigmatism} = (s_v - s_u) / [(s_u + s_v) / 2]$$

– the difference between the calculated source waist Z_0 distances from the lens principal plane divided by the average Z_0 distance.

$$\text{Waist Asymmetry} = 2W_{0u} / 2W_{0v}$$

– the ratio of the calculated source diameters.

$$\text{Divergence Asymmetry} = \text{Theta}_u / \text{Theta}_v$$

– the ratio of the calculated source divergence angles.

Important: The source Z_{0u} , Z_{0v} values are given as measured from the front of the lens holder, not from the lens principal plane. This is because this is a distance you can easily measure.

For this particular beam Z_0 was 860 ± 5 mm, so the estimates are accurate to a surprisingly good few %.

M ² _u	1.05	M ² _v	1.03
2W _{0u}	570.0 um	2W _{0v}	587.3 um
Z _{0u}	869.69 mm	Z _{0v}	882.36 mm
Z _r _u	384.71 mm	Z _r _v	411.04 mm
Theta _u	1.5 mr	Theta _v	1.4 mr
NA _u	0.001	NA _v	0.001

14) Save the Data

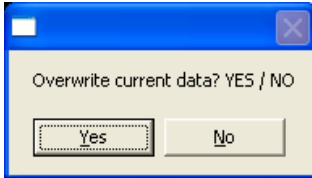

Press **Save M2** to save the results as a *.wcf file. If you forget to do so, a warning will appear before you start another M2 scan.

<<**Decrement Sample** and **Increment Sample**>> scan through the planes of the individual measurements.

Saved files contain the original images, so you may switch between **Use clip widths at 0 and 90 deg** and **Use major/minor widths**.

When **Use major/minor widths** is selected, **Use ISO 11146 compliant diameters and angles** is automatically selected and any clip level is ignored.

If the beamwaist profile in the propagation direction – the z direction – is either too flat or too 'V' shaped, the fit will be poor.

Click on **Show 3D view** to see the visually more satisfying 3D view shown below.

Click on **Export Data** to export the data to an **M2data.txt** file in Notepad, which may be saved for subsequent analysis, and from which the data may be exported into Excel.

Click on **Recall M2** to browse for and open previously saved files.

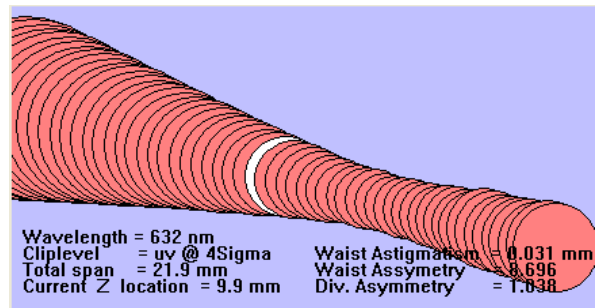

15) Second time around

When the software is closed, it saves the current settings.

If the laser power and alignment have not changed substantially, all you need to do is rerun the software.

If anything has changed revisit that section only.

16) Support

If you get an error message, press Alt, **Prt Sc** to put it to the clipboard, and then **Ctrl V** to put it into an email message. Sometimes these are diagnostic warnings rather than something more significant, and clicking the **OK** button allows you to proceed.

If you get a result which makes no sense, and rechecking the procedure did not help, then:

- 1) Scan through the saved images to see whether or not you have a dirt, dust, exposure time or Capture block issue affecting the image.
- 2) If 1) showed nothing that explained the problem, then save a ***.m2_wcf** file or at least an ***.wcf** image saved from the data set. Email the file with comments to: service@gentec-eo.com.

Then, as necessary, call 418-651-8003, 8:30 to 17:00, Eastern time zone. (GMT -5 hours).

[Note that ***.m2_wcf** files can be large, ten's of MB. We can receive large files, but your email server may restrict attachment size. In that case, either put them to an FTP location on your server and tell us how to download them, or try using <http://www.sendthisfile.com>.]

17) Manual M² (with a different translation Stage)

If you have a Beamage camera but no M2DU unit, the procedure is identical, particularly with respect to alignment, exposure, laser safety, capture block, etc.

Before trying to perform a Manual M², you **must** first read and understand the full document carefully except for items relating *specifically* to the parts list and assembly of/with the M2DU unit.

Exceptions to the procedure are as follows:

- Stage Travel:** Determine the length of travel of your alternative z 'stage', be it motorized or manual.
- Stage Readout:** The 'stage' must have a readout in mm, be it digital or manual.
- Source diameter & location.** To additionally determine the waist diameter & z location of the source beam:

Lens: You need to know the focal length (mm), and back focal length (mm) of your lens. Enter in the table below.

Lens mount: You need to determine the distance **Zo Delta** (mm) from the front of your lens mount to the rear principal plane of the lens. Enter in the table below.

Lens mount: You need to determine the distance **LPPSO** (mm) from the lens rear principal plane to the sensor plane *when at 0 on your measurement scale*. Enter below.

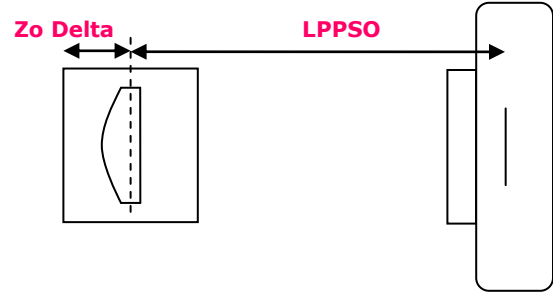

Lens focal length	Lens back focal length	= LPPSO (Enter in M2 dialog) Lens Principal Plane to Sensor at 0	Zo Delta (Enter in M2 dialog) Front of lens mount to Principal Plane

- Move the camera in z and determine that the waist is around 50% to 75% along an attainable range of travel.
- At Step 8) above when the **M-Squared Setup** dialog screen opens, enter the listed parameters, *plus* the **Translation stage maximum travel**.

M-Squared Setup ✕

Wavelength in nm:

LPPSO [see User Guide]:

Lens Focal Length in mm:

Zo Delta [from table in User Guide]:

Translation stage maximum travel [if manual]:

Averages per Sample: 1 2 3 4 5 6 8 10

Number of Samples: 5 10 15 20 25 40 60

- f) When you start the software with no M2DU stage connected the **M-Squared Dialog** will say **Manual mode** below the graphic area of the dialog.
- g) Set the camera to your start position, which need not be zero on the scale. Press **Go** and let the image and exposure stabilize. Press **Start M2**. [Obviously **Auto M2 Setup** is grayed out if you do not have an M2 stage.] The following dialog will appear:

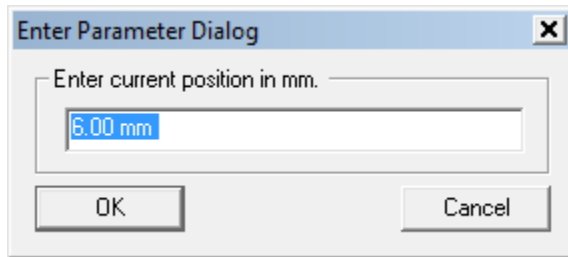

The position highlighted in blue is the software's best guess at what the position will be based upon the entered stage range and the number of steps.

You may use these values or you may ignore them.

Enter the actual z position (no need to include **mm**) rather than blue value. Press **OK**.

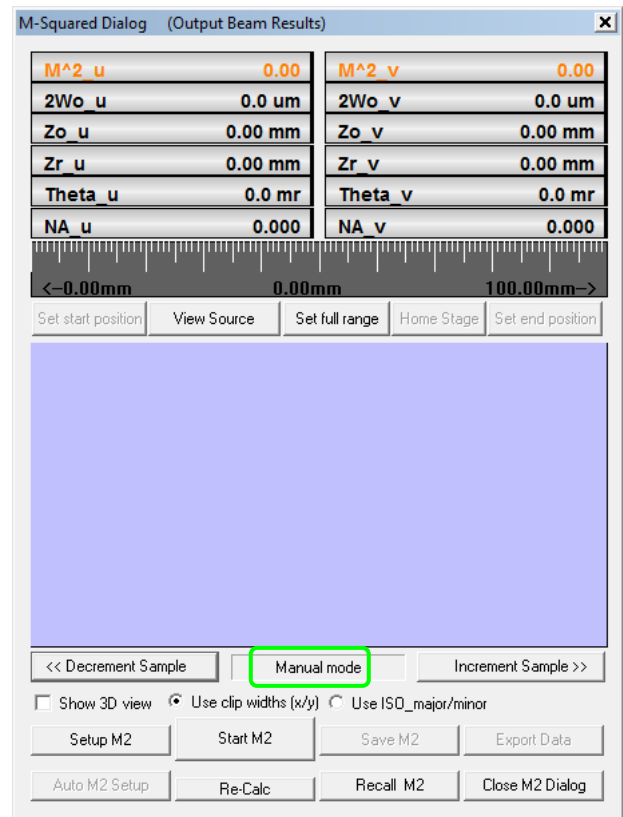

A dialog box will appear with a recommended position. You may use the recommended position or one of your choosing. Once the position is set, press **OK** and after the image exposure has stabilized, the next reading will be taken.

This dialog box will reappear with a different position option.

If you take too long between readings, the dialog shown right will appear. Simply select **No** to cancel it.

Follow through the sequence until the requested number of samples has been entered, at which stage the results will appear instead of a dialog box.

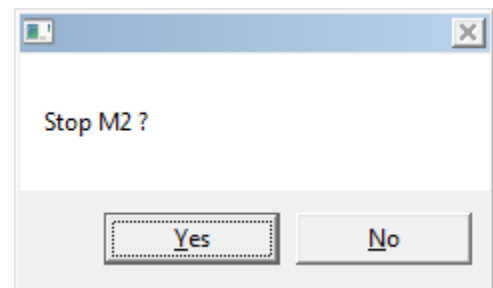

- h) As you read about using the M2DU stage, you will probably have to iterate the positioning and the number of samples until the curve looks right and there are no **Warnings**.

GENTEC-EO WORLDWIDE



LEADER IN
LASER BEAM
MEASUREMENT
SINCE 1972

CANADA

445 St-Jean-Baptiste, Suite 160
Quebec, QC, G2E 5N7, Canada

T (418) 651-8003

F (418) 651-1174

1 (888) 5GENTEC (Canada and USA only)
service@gentec-eo.com

UNITED STATES

5825 Jean Road Center
Lake Oswego, OR, 97035, USA

T (503) 697-1870

F (503) 697-0633

1 (888) 5GENTEC (Canada and USA only)
service@gentec-eo.com

Calibration Centers

445 St-Jean-Baptiste, Suite 160
Quebec, QC, G2E 5N7, Canada

Werner von Siemens Str. 15
82140 Olching, Germany